

SEC-ASD 532

Aspirating Smoke Detector

As of production version 151015 and FW version 01.00.08

The SEC-ASD 532 aspirating smoke detector has the task of continuously taking air samples via a sampling pipe tube network from a monitored area and feeding the samples to a smoke sensor.

The SEC-ASD 532 consists of the detector housing and a sampling pipe tube network. The sampling pipe has several sampling holes whose size is such that each hole extracts the same amount of air. The sampling pipe may be I-, U-, T-, H-, or E-shaped. The sampling pipes are usually symmetrically designed. Asymmetrical sampling pipe tube networks can also be implemented with the help of the "ASD PipeFlow" calculation software.



Fig. 1 SEC-ASD 532

Description

Integrated in the detector housing is a fan which, in conjunction with the sampling pipes, ensures an uninterrupted supply of air to the detector housing. Airflow monitoring detects any pipe blockages and pipe breakages in the sampling pipe.

The SEC-ASD 532 can be equipped with the following smoke sensor type:

- SSD 532-1 Sensitivity range 0.5 %/m to 10%/m
- SSD 532-2 Sensitivity range 0.1%/m to 10%/m
- SSD 532-3 Sensitivity range 0.02%/m to 10%/m

The SEC-ASD 532 aspirating smoke detector has two slots for additional modules. The following modules can be fitted:

- XLM 35 eXtended Line Module
- RIM 36 Relay Interface Module with 5 relays (max. units);
- SIM 35 Serial Interface Module

The SEC-ASD 532 can be connected to a superordinate FACP by means of potential-free change-over contacts.

With the installation of an **XLM 35**, the SEC-ASD 532 can be ideally connected via the addressable loop to the SecuriFire and Integral fire alarm systems.

The **RIM 36** is available as a further installation option. This module enables the availability of all three pre-signal levels as well as the states "smoke sensor dirty" and "LS-Ü blockage" as relay contacts. The relays are also freely programmable via the "ASD Config" configuration software.

Up to 250 ASDs can be networked with the **SIM 35**; they can then be visualised and operated from a PC using "ASD Config".

The SEC-ASD 532 aspirating smoke detector can be used for:

- **Equipment monitoring:** EDP systems, electrical distributors, switch cabinets, etc.
- **Space surveillance:** EDP rooms, ultra-clean rooms, warehouses, hollow floors, protection of cultural assets, transformer stations, prison cells, etc.

The SEC-ASD 532 can also be deployed in areas where normally conventional point detectors are used. Local regulations and provisions must be observed from case to case.

The response behaviour of the SEC-ASD 532 has been tested in compliance with EN 54-20, Class A, B and C.



When setting up ASD 532 fire alarm systems, the information and specifications in "**Technical Description ASD 532**" must be observed and adhered to. This includes among others:

- **General** Section 1
- **Planning** Section 4
- **Mounting** Section 5
- **Installation** Section 6
- **Commissioning** Section 7
- **Operation** Section 8

Opening the detector housing



Press the rotary snap locks down **firmly** with a screwdriver (at least No. 5) toward the housing base and then **turn 90°** to open them. The position of the lock slit shows the current status:

- angled approx. 45° toward detector housing corner = closed;
- angled approx. 45° toward detector housing edge = open.

In either position the rotary snap locks **must** snap into place.

Connection

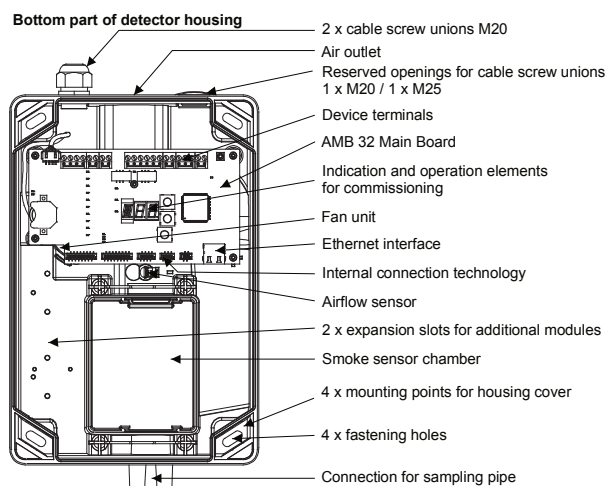

Fig. 2 Inside view of the ASD 532

Device connections on the AMB 32

The electrical connection is by means of plug-in terminals.

Terminal	Signal	
1	+14 to +30 VDC ①	Main power supply line
2	0 V	
3	+14 to +30 VDC ①	Redundant power supply line
4	0 V	
5	+ Supply (for OC consumers)	
6	Output Fault, OC (all events)	
7	Output Alarm, OC	
8	Rel. 1 "NO"	Fault
9	Rel. 1 "NC"	
10	Rel. 1 "COM"	
11	Rel. 2 "NO"	Alarm
12	Rel. 2 "NC"	
13	Rel. 2 "COM"	
14	Input Reset external +	Opto-isolator input reset
15	Input Reset external -	
16	OEM +	Opto-isolator input OEM
17	OEM -	
18	PWR-O+	Power supply for accessory bus (14 – 30 VDC)
19	PWR-O-	
20	Data-	RS485 connection for accessory bus
21	Data+	



- In some cases actuations via the OEM input may **not** comply with the requirements of **EN 54-20** (use only consulting with the manufacturer).
- The OEM input is **not** line monitored.

XLM 35, RIM 36, SIM 35 terminal assignment

The terminal assignments of the XLM 35, RIM 36 and SIM 35 can be found in the corresponding data sheets T 140 088 (XLM 35), T 140 364 (RIM 36) and T 140 011 (SIM 35).

Wiring principle



Examples of and information on the wiring principle can be found in the Technical Description ASD 532, T 140 421, Sec. 6.

Using the smoke sensors

The SEC-ASD 532 ships with the smoke sensor not fitted. It is application specific (according to required sensitivity range), purchased from the manufacturer, and installed after the detector housing is mounted (see Fig. 3).



- Always leave the smoke sensor inside its protective packaging until just before it is to be installed in the detector housing.
- Depending on the situation – e.g. if there is a long time between mounting and commissioning or if the environment is extremely dusty (construction work) – the smoke sensor should be installed just before commissioning the SEC-ASD 532.
- Before installing the smoke sensor check that the insect protection screens are properly fitted to the smoke sensor chamber at the air inlet and outlet.
- The smoke sensor chamber must be absolutely free of any dirt and/or dust. Remove any residue resulting from mounting the detector housing.

Check the installation position when installing the smoke sensor. The connector plug of the smoke sensor must be face away from the slots of the additional modules. The anti-twist rib on the smoke sensor case prevents an incorrect installation position.

The smoke sensor is secured inside the ASD housing using the two lock clamps. The electrical connection to the AMB 32 main board is accomplished with the supplied ribbon cable.

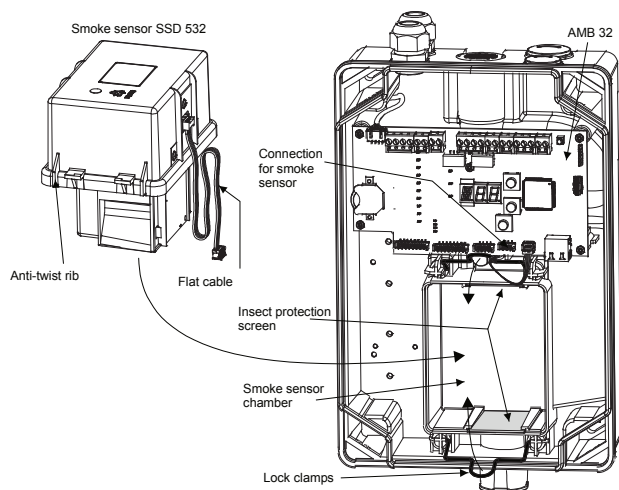

Fig. 3 Deploying the smoke sensors

Displays on the control unit

Several LEDs on the control unit indicate the current state of the SEC-ASD 532.

Function / state	Operation	Alarm	Fault	Det. dusty / dirty	Smoke level
	green	red	yellow	yellow	yellow
System Off (no voltage)					
System inactive (reset external)	On		½ T		
Smoke sensor Off (from FACP)	On		½ T		
Quiescent state	On				
Pipe blockage/breakage, delay running ①	On		1 T		
Pipe blockage/breakage, fault triggered	On		On		
Fan tacho signal missing	On		On		
Fault triggered	On		On		
Smoke level 1–10 ②	On				On
Pre-signal 1, 2, 3 ②	On				1 T
Alarm	On	On			
Smoke sensor dusty	On			1 T	
Smoke sensor dirty	On			½ T	
Smoke sensor faulty	On			On	



① No fault triggered (triggers only after delay time has expired → "Fault" continuously lit).

② The LED of the respective smoke level 1–10 (corresponds to 10–100% of alarm threshold) is continuously lit when exceeded. If a pre-signal is programmed on this level, the LED subsequently begins to flash (default: VS 1 = level 3, VS 2 = level 5, VS 3 = level 7).

T = flashing display; ½ s cycle / 1 s cycle / 2 s cycle

Indicators on the AMB 32 main board

The AMB 32 has a 3-digit segment display enabling the following outputs and displays:

- flashing, point, and **AL** = **Autolearning** running;
- flashing point and continuously lit point = day/night control active;
- switch position **E** = event memory (99 events **E01** to **E99**), for more detailed information see T 140 421, Sec. 8.5.3;
- switch position **F** = firmware version, for more detailed information see T 140 421, Sec. 7.3.6;
- Push button "UP" = the set configuration (**A11** to **C31**, **W01** to **W44**, **X01** to **X03**), see also "Programming";
- switch position **V** = airflow values (airflow rate), for more detailed information see T 140 421, Sec. 7.6.1

Programming

The SEC-ASD 532 has several switch positions that are configured with permanently assigned parameters:

- normative system limits according to EN 54-20, Class A to C, settings **A11** to **C31**;
- non-normative system limits, settings **W01** to **W44**;
- Configurable positions for saving the settings after using "ASD PipeFlow" and/or changing the device configuration using the configuration software "ASD Config" or SecurFire or Integral-FACP (SLM 35), **X01** to **X03**.



The parameters are configured and stored ex works with default states and values to meet the triggering properties required by EN 54-20. Changing the parameters may result in non-compliance with EN 54-20. Adjustments or modifications to the SEC-ASD 532 using "ASD Config" may be carried out only by the manufacturer or by persons under the supervision of and trained by the manufacturer.

Switch positions on the Main Board AMB 32

Pos.	Area / Display	Purpose
A	A11	Normative system limits compliant with EN 54-20, Class A
b	b11 / b21	Normative system limits compliant with EN 54-20, Class B
C	C11 / C21 / C31	Normative system limits compliant with EN 54-20, Class C
E	E01 to E99 ↳ G00 to G99	Event memory E01 – E99 ↳ Event group G00 – G99
F	F00 to F99 (3 x)	Displays firmware version
I	IA1 IF1 IP1 IE1	Triggering; test alarm (IA1) Test fault (IF1) Test pre-signal (IP1) Test alarm 2 (IE1)
o	o00	Logs off additional modules (optional modules)
T	Y10 to Y99 / M01 to M12 d01 to d31 / H00 to H23 M00 to M59	Polling (RE) and adjusting (SE) the date and time
U	U01	Executes initial reset
V	V01, 000 to 255	Volume rate of flow output in %
W	W11 to W48	Non-normative system limits
X	X01 to X03	Configurable switch positions



The table lists only the available switch positions. For information about the input procedure please refer to Technical Description T 140 421, Sec. 8.3.

System limits without ASD PipeFlow calculation

The system limits apply to the planning without using the ASD PipeFlow calculation software. There are two areas, with the following meaning:

- **Normative system limits** compliant with EN 54-20, Class A to C,
Switch positions **A11** to **C31**;
- **Non-normative system limits**,
Switch positions **W01** to **W44**.

Normative system limits

Stored under switch positions **A11** to **C31** are values which are necessary in terms of alarm response sensitivity and airflow monitoring for compliance with EN 54-20 Class A to C. The switch position designation is deciphered as follows:

- First digit Response grade **A, b, C** compliant with EN 54-20;
- Second digit System limit **1, 2, 3** (pipe topology);
- Third digit Number of tube networks **1, (only 1 possible)**.

Example: **b21** Response grade **b** / system limit **2** / **1** sampling pipe tube network.

Non-normative system limits

Switch positions **W01** to **W44** contain system limits which fulfil only the alarm response sensitivity compliant with EN 54-20 Class A to C, but not the normative limits with regard to airflow monitoring. As they are identical with the system limits **A11** to **C31** in terms of tube topology (tube network length, number of sampling holes), the switch positions **W01** to **W44** are also included in the tables below. Additional information about switch settings **W01** to **W44** concerning number of tube networks and airflow monitoring can be found in Technical Description T 140 421, Sec. 4.4.4.4.



Switch settings **W01** to **W44** may be used only after consulting with the manufacturer. The airflow monitoring values stored under those switch positions are not tested in accordance with EN. For more information on using the table of system limits, please refer to the Technical Description T 140 421, Sections 4.4.4.3 and 4.4.4.4.

Table of system limits for planning without ASD PipeFlow calculation

Compliant with EN 54-20, Class A (highly sensitive)

Shape	System limit	Switch position compliant with EN 54-20	Switch position not standards compliant	Smoke sensor type SSD 532	Alarm threshold (%/m)	Length from ASD to last T-piece/cross	Max. length from ASD to farthest sampling hole	Number of sampling holes per sampling branch	Max. total length of sampling pipe per tube network (smoke sensor)
I	1	A11	W01 – W04	–3	0.03	---	40 m	1 – 6	40 m
U / T	1	A11	W01 – W04	–3	0.03	1 – 20 m	40 m	1 – 3	80 m
H	1	A11	W01 – W04	–3	0.03	1 – 20 m	25 m	1 – 2	100 m
E	1	A11	W01 – W04	–3	0.03	1 – 20 m	30 m	1 – 3	90 m

Compliant with EN 54-20, Class B (sensitive)

I	1	b11	W09 – W12	–2	0.17	---	30 m	1 – 4	30 m
	2	b21	W17 – W20	–3	0.08	---	40 m	5 – 8	40 m
U / T	1	b11	W09 – W12	–2	0.17	1 – 20 m	30 m	1 – 2	60 m
	2	b21	W17 – W20	–3	0.08	1 – 20 m	40 m	3 – 4	80 m
H	1	b11	W09 – W12	–2	0.17	1 – 20 m	20 m	1	80 m
	2	b21	W17 – W20	–3	0.08	1 – 20 m	25 m	2 – 3	100 m
E	1	b11	W09 – W12	–2	0.17	1 – 20 m	20 m	1	60 m
	2	b21	W17 – W20	–3	0.06	1 – 20 m	30 m	2 – 3	90 m

Compliant with EN 54-20, Class C (standard)

I	1	C11	W25 – W28	–1	0.62	---	30 m	1 – 4	30 m
	2	C21	W33 – W36	–2	0.37	---	40 m	5 – 8	40 m
	3	C31	W41 – W44	–2	0.15	---	60 m	9 – 12	60 m
U / T	1	C11	W25 – W28	–1	0.62	1 – 10 m	20 m	1 – 2	40 m
	2	C21	W33 – W36	–2	0.37	1 – 20 m	30 m	3 – 4	60 m
	3	C31	W41 – W44	–2	0.15	1 – 20 m	40 m	5 – 6	80 m
H	1	C11	W25 – W28	–1	0.62	1 – 10 m	15 m	1	60 m
	2	C21	W33 – W36	–2	0.37	1 – 20 m	20 m	2	80 m
	3	C31	W41 – W44	–2	0.15	1 – 20 m	25 m	3 – 4	100 m
E	1	C11	W25 – W28	–1	0.62	1 – 10 m	20 m	1 – 2	60 m
	2	C21	W33 – W36	–2	0.37	1 – 20 m	25 m	3	75 m
	3	C31	W41 – W44	–2	0.15	1 – 20 m	30 m	4 – 5	90 m

Sampling holes for planning with ASD PipeFlow calculation

The tables below show the corresponding hole diameters for the numbers in Fig. 4 depending on the number of sampling holes per sampling branch.

I-shaped sampling pipes												
Number of sampling holes	Hole diameter in mm for the sampling hole number as of ASD											
	1	2	3	4	5	6	7	8	9	10	11	12
1	5.0											
2	4.0	5.0										
3	4.0	4.0	5.0									
4	3.5	3.5	4.0	5.0								
5	3.5	3.5	3.5	4.0	5.0							
6	2.5	2.5	2.5	2.5	3.0	5.0						
7	2.5	2.5	2.5	2.5	2.5	2.5	5.0					
8	2.5	2.5	2.5	2.5	2.5	2.5	2.5	5.0				
9	2.5	2.5	2.5	2.5	2.5	2.5	2.5	2.5	5.0			
10	2.0	2.0	2.0	2.5	2.5	2.5	2.5	2.5	3.0	7.0		
11	2.0	2.0	2.0	2.0	2.5	2.5	2.5	2.5	2.5	4.0	7.0	
12	2.0	2.0	2.0	2.0	2.0	2.0	2.5	2.5	2.5	2.5	4.0	7.0

U/T-shaped sampling pipes						
Number of sampling holes per sampling branch	Hole diameter in mm for the sampling hole number from the ASD					
	1	2	3	4	5	6
1	5.0					
2	4.0	5.0				
3	4.0	4.0	5.0			
4	4.0	4.0	4.0	5.0		
5	4.0	4.0	4.5	5.0	6.5	
6	3.0	3.0	3.5	3.5	4.0	6.5

H/E-shaped sampling pipes				
Number of sampling holes per sampling branch	Hole diameter in mm for the sampling hole number from the ASD			
	1	2	3	4
1	5.0			
2	4.0	5.0		
3	4.0	4.0	5.5	
4 (E-shaped only)	3.0	3.0	3.5	5.5

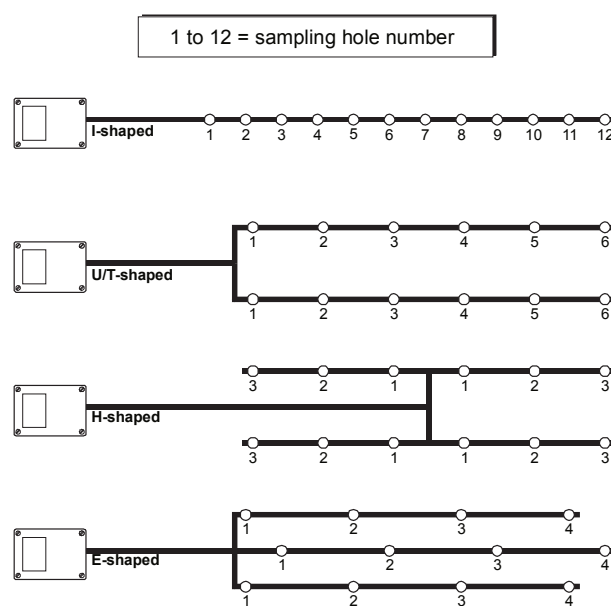

Fig. 4 Size of sampling holes

Configuration options, Table A:

The following criteria can be set for each smoke sensor / sampling pipe. Also, the criteria for day/night control can be separately set. Configuration changes are saved on one of the freely configurable switch positions **X01** to **X03**.

Sector • Parameters	Default setting	Range	Resolution / Levels	Saving after change
Alarm 2				
• Alarm 2 On / Off	Off	Off / On		X01 – X03
• Sensitivity (always at least 20% above alarm)	1%/m	-10%/m	0.0002%/m	X01 – X03
• Alarm 2 delay	2 s	0 s – 60 s	1 s	X01 – X03
• Alarm 2 latching	On	On / Off		X01 – X03
• Holding time for area switchover (AI 2 to AI)	20	10 – 250	1 s	X01 – X03
Alarm				
• Alarm threshold (dependent on smoke sensor type and response class according to EN 54-20)	C11	0.02 – 10%/m 0.1 – 10%/m 0.5 – 10%/m	0.0002%/m	X01 – X03
• Smoke level value averaging (number)	4	1 – 10	1	X01 – X03
• Alarm delay	2 s	0 s – 60 s	1 s	X01 – X03
• Alarm cascading	Off	Off / On		X01 – X03
• Alarm latching	On	On / Off		X01 – X03
Pre-signal				
• Pre-signal 1 On / Off	On	On / Off		X01 – X03
• Pre-signal 2 On / Off	On	On / Off		X01 – X03
• Pre-signal 3 On / Off	On	On / Off		X01 – X03
• Pre-signal 1 (100% = alarm threshold)	30%	10 – 90%	10%	X01 – X03
• Pre-signal 2 (100% = alarm threshold)	50%	VS 1 + 10 – 90%	10%	X01 – X03
• Pre-signal 3 (100% = alarm threshold)	70%	VS 2 + 10 – 90%	10%	X01 – X03
• Pre-signal delay (VS 1 – VS 3)	2 s	0 s – 60 s	1 s	X01 – X03
• Pre-signal latching	Off	Off / On		X01 – X03
Smoke sensor dust/dirt				
• Smoke sensor dust On / Off	On	On / Off		X01 – X03
• Smoke sensor dirt On / Off	On	On / Off		X01 – X03
• Dust threshold (% of AI)	50%	5 – 60%	5%	X01 – X03
• Dirt threshold (% of AI)	75%	65 – 90%	5%	X01 – X03
• Dust latching	On	On / Off		X01 – X03
• Dirt latching	On	On / Off		X01 – X03
• Smoke sensor fault delay	30 s	0 s – 60 s	1 s	X01 – X03
Airflow monitoring				
• LS-Ü pipe blockage On / Off	On	On / Off		X01 – X03
• LS-Ü pipe breakage On / Off	On	On / Off		X01 – X03
• LS-Ü sensitivity ①	±20% ①	±1 – ±70%	± 1%	X01 – X03
• LS-Ü value averaging (number)	20	1 – 30	1	X01 – X03
• LS-Ü delay ①	300 s ①	2 min – 60 min	10 s / 1 min	X01 – X03



① Increased values are configured for switch settings **W01** to **W44**; these are **not** tested for EN compliance (see Technical Description T 140 421, Sec. 4.4.4.4).

Configuration options, Table B:

The following criteria apply to the entire SEC-ASD 532. Configuration changes are stored in connection with the adjustments from Table A, likewise on one of the user configurable switch positions **X01** to **X03**.

Sector • Parameters	Default setting	Range	Resolution / levels	Saving after change
Autolearning				
• Autolearning On / Off	Off	On		X01 – X03
• Autolearning duration	3 days	1 min to 14 days	min, h, days	X01 – X03
• Autolearning factor (of measured AI threshold)	1.5	1.1 – 10 x		X01 – X03
Day/night control & weekday control				
• Day/night control On / Off	Off	Off / clock / FACP		X01 – X03
• Day start time	06:00	00:00 – 24:00	15 min	X01 – X03
• Night start time	20:00	00:00 – 24:00	15 min	X01 – X03
• Weekday control	On	Mon. to Sun.	days	X01 – X03

→→

Continuation, Table B:

General faults				
• Lithium battery / clock fault	On	On / Off		X01 – X03
Fan				
• Fan speed	Level II	Level I to III	1	X01 – X03
Deactivate / switch off sensor				
• Smoke sensor	On	On / deactivated		X01 – X03

Configuration options, Table C:

Independent configurations. These can be changed regardless of the switch position in the SEC-ASD 532.

Sector	Default setting	Selection
• Parameters		
Clock		
• Year, month, day, hour, minute	---	minutes – year
Relay / OC output / reset key / various		
• Relay 1, 1 st RIM 36	Pre-signal 1 smoke sensor	in accordance with “Relay allocation configuration options”
• Relay 2, 1 st RIM 36	Pre-signal 2 smoke sensor	
• Relay 3, 1 st RIM 36	Pre-signal 3 smoke sensor	
• Relay 4, 1 st RIM 36	Smoke sensor dirt	
• Relay 5, 1 st RIM 36	Sampling tube blockage	
• Relay 1, 2 nd RIM 36	--	
• Relay 2, 2 nd RIM 36	--	
• Relay 3, 2 nd RIM 36	--	
• Relay 4, 2 nd RIM 36	--	
• Relay 5, 2 nd RIM 36	--	
• Reset key On / Off	On	On / Off
• Perform initial reset	---	On / Off
• OEM input signal	Off	Off / OEM input alarm / OEM input fault / Day/night switching
• Isolate smoke sensor	Normal operation	Isolate / normal operation

Relay allocation configuration options:

The following criteria are freely programmable on max. 10 relays (5 units on 1st RIM 36, 5 units on 2nd RIM 36):

Smoke sensor / LS-Ü	General
Smoke sensor alarm	Fan fault
Pre-signal 1 smoke sensor	Operating voltage fault
Pre-signal 2 smoke sensor	Initial reset fault
Pre-signal 3 smoke sensor	Lithium battery / clock fault
Smoke sensor dust	
Smoke sensor dirt	
Smoke sensor fault	
Sampling tube blockage	
Pipe breakage sampling tube	
Alarm 2 sampling pipe	

The criteria can also be allocated using the OR function (e.g. smoke sensor dust or dirt together on one relay).

Commissioning

When commissioning the SEC-ASD 532, it is necessary to perform an initial reset to automatically adjusting the airflow monitoring on the connected sampling pipe.

If the SEC-ASD 532 is operated without "ASD PipeFlow" calculation, the commissioning can be carried out directly using the "EasyConfig" process directly on the SEC-ASD 532.

For projects in which the ASD PipeFlow calculation software was used or in which customer-specific adjustments to the device configuration are required, use the **ASD Config** configuration software.

Starting up



Before the SEC-ASD 532 is switched on, make sure all the precautions required for its operation have been taken (see also T 140 421, Sec. 7.1).

- Sampling pipe correctly laid and connected;
- Smoke sensors built in and connected;
- Isolation strip on the lithium battery (AMB 32) removed.

Startup sequence and procedure:

1. Switch on supply voltage (FACP); the next procedure can be carried out while the fan is ramping up to its definitive speed (takes about 100 s). **The system is immediately armed for alarm.**
2. "EasyConfig": Select necessary switch setting for operation according to "System limit table" (e.g. "b21") → see "Re-programming".
- or:
"ASD Config": after making adjustments to the configuration (alarm threshold according to ASD PipeFlow, other criteria according to Tables A and B) select switch position "X01", "X02" or "X03".
3. Set date and time via AMB 32 on "EasyConfig" or from "ASD Config" (adopt settings from PC).
4. Following a **minimum waiting time of 2 min** after switching on, an initial reset must be performed (possible only via AMB 32) → see "Initial reset".
5. The SEC-ASD 532 is now ready for operation.

Re-programming

Example: Response grade B, system limit 2, SEC-ASD 532, switch position required **b21**.

Measure	Indicator	Procedure Remark
	Switch settings W01 to W44 may be used only after consulting with the manufacturer. The airflow monitoring values stored under those switch positions are not tested in accordance with EN.	
1. Press the "UP" key	Flashing C31	• Displays the default setting
2. Press "UP" key twice until display shows b	in succession A / b	• Displays the switch position group b
3. Press the "OK" key	b11	• Displays the smallest possible position in group b
4. Press "UP" until display shows b21	in succession b11 / b21	• Displays the possible positions in group b
5. Press the "OK" key	flashing b - - (approx. 4 x)	• New setting is programmed
6. Check: Press the "UP" key	Flashing b21	• Displays the new setting

Initial reset

Measure	Indicator	Procedure Remark
	Before performing an initial reset after switching on the SEC-ASD 532, a waiting time of at least 2 min must be observed.	
1. Press the "UP" key	Flashing C31 or other	• Displays the default setting or the installation-specific switch position
2. Press the "UP" key several times until display shows U	in succession A to U	• Displays the switch position group U
3. Press the "OK" key	U01	• Displays initial reset On
4. Press the "OK" key again	flashing U - - (5 to max. 120 s)	• Initial reset in progress
5. Wait	flashing point (watchdog indicator)	• Initial reset completed

Measurements / Commissioning protocol

Carry out the following measurements:

- Measure voltage at terminals 1 (+), 2 (-) (also terminals 3 and 4 if redundant supply) → target value = 17.6 to 27.6 VDC
- Airflow values in switch settings **V** (see Technical Description T 140 421, Sec. 7.6.1)

The commissioning protocol is like a personal history of the SEC-ASD 532 and should therefore be filled out conscientiously and completely and stored in the SEC-ASD 532. If required, a copy can be made and stored in the system dossier.

Checking fault and alarm release

Test	Procedure	Action
	Block or switch off fire incident control and remote alerting on the superordinate FACP.	
Check airflow monitoring	Tape over the sampling holes (adhesive tape); the number depends on the pipe configuration.	<ul style="list-style-type: none"> As soon as the resulting change in airflow rate exceeds $\pm 20\%$ (which can also be checked using switch position V), the "Fault" LED begins to flash. Once the LS-Ü delay (300 s) has elapsed, the ASD triggers a fault → fault on FACP ①.
Check alarm release	Impose smoke at the maintenance sampling hole or sampling hole.	<ul style="list-style-type: none"> ASD triggers an alarm → alarm on FACP; check for correct alarm transmission (zone/range release) on the FACP ①. Any pre-signals will also release.

① Reset the SEC-ASD 532 between each check (please note: resetting the ASD does not reset the FACP).

Article numbers / Spare parts

Short designation	Article number
Aspirating Smoke Detector SEC-ASD 532	11-2000003-01-XX
Smoke sensor SSD 532-1; 0.5%/m – 10%/m	11-2000004-01-XX
Smoke sensor SSD 532-2; 0.1%/m – 10%/m	11-2000004-02-XX
Smoke sensor SSD 532-3; 0.02%/m – 10%/m	11-2000004-03-XX
eXtended Line Module XLM 35	11-2200003-01-XX
RIM 36 Relay Interface Module	11-2200005-01-XX
SIM 35 Serial Interface Module	11-2200000-01-XX
SMM 535 Serial Master Module	11-2200001-01-XX
SD memory card (industrial version)	11-4000007-01-XX
AMB 32 Main Board	11-2200013-01-XX
Aspirating Fan Unit AFU 32, complete	11-2200008-01-XX
Air Flow Sensor AFS 32	11-2200007-01-XX
Insect Protection Screen IPS 35 (set of 2)	11-2300012-01-XX
Lithium battery	11-4000002-01-XX
Cable screw union M20 (set of 10)	11-4000003-01-XX
Cable screw union M25 (set of 10)	11-4000004-01-XX
UMS 35 Universal Module Support	4301252.0101
Technical description SEC-ASD 532	T 140 421
Material for the sampling pipe	T 131 194
Commissioning protocol	T 140 423
Data sheets	XLM 35 T 140 088
	RIM 36 T 140 364
	SIM 35 T 140 011
	SMM 535 T 140 010
AFU 32 installation instructions	T 140 426

Dimensioned drawing

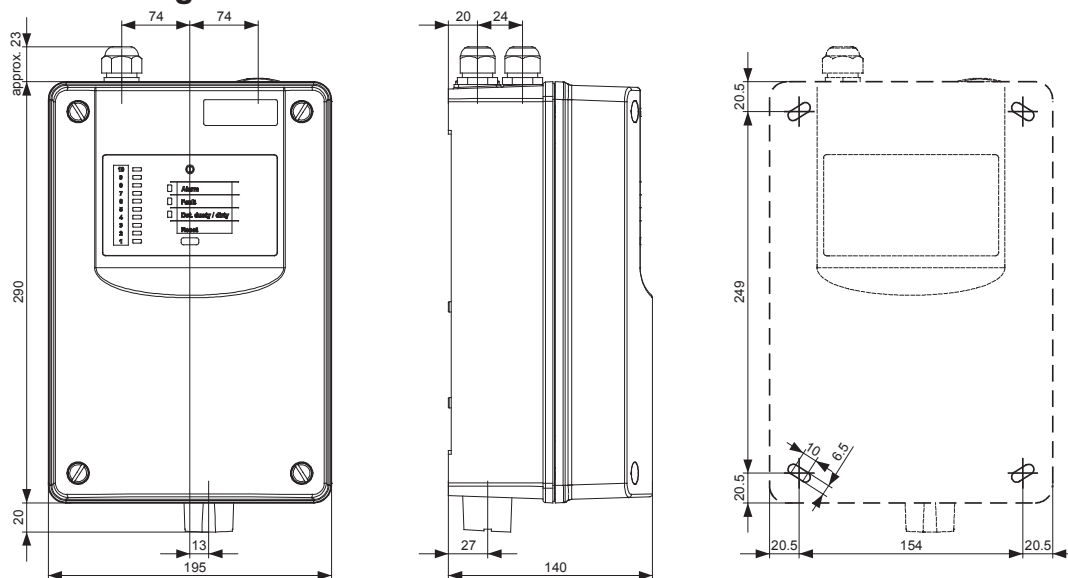

Fig. 5 Detector housing dimensioned drawing

Technical data

Type	SEC-ASD 532		
Supply voltage range	14 to 30	VDC	
Max. power consumption, measured in	typical		
Fan speed level III and at →	14 VDC ①	24 VDC	
SEC-ASD 532	Quiescent / fault	approx. 170	approx. 100 mA
	Alarm	approx. 200	approx. 115 mA
	additionally with 1x RIM 36	approx. 30	approx. 15 mA
	additionally with 2x RIM 36	approx. 60	approx. 30 mA
	additionally with XLM 35	approx. 15	approx. 5 mA
	additionally with SIM 35	approx. 15	approx. 5 mA
	SMM 535 (not from ASD but rather from PC via USB connection)		max. 100 mA
Switch-on current peak ② (caused by EMC protection elements on the ASD supply input)		approx. 5	A
		for max. 1	ms
Sampling pipe length	see T 140 421, Sec. 4.2.1		
Sampling pipe diameter, typical (inner/outer)	Ø 20 / 25 mm		
Max. number of sampling holes	see T 140 421, Sec. 4.2.1		
Sampling hole diameter	Ø 2 / 2.5 / 3 / 3.5 / 4 / 4.5 / 5 / 5.5 / 6 / 6.5 / 7 mm		
Response range	EN 54-20, Class A, B, C		
Protection type compliant with IEC 529 / EN 60529 (1991)	54		IP
Ambient conditions compliant with IEC 721-3-3 / EN 60721-3-3 (1995)	3K5 / 3Z1		Class
Extended ambient conditions:			
• Detector housing temperature range	-20 – +60		°C
• Sampling pipe temperature range	-20 – +60 ③		°C
• Max. permissible temperature fluctuation in detector housing and sampling pipe operation	20 ③		°C
• Max. permissible storage temperature for detector housing (without condensation)	-30 – +70		°C
• Ambient pressure difference between detector housing and sampling pipe (sampling holes)	must be identical		
• Humidity ambient condition for detector housing (transient without condensation)	95 ③		% rel. h
• Humidity ambient condition (continuous)	70 ③		% rel. h
Max. loading capacity, relay contact	50	VDC	
	1	A	
	30	W	
Max. loading capacity per OC output (dielectric strength 30 VDC)	50		mA
Plug-in terminals	2.5		mm ²
Cable entry for cable Ø	Ø 5 – 12 (M20) / Ø 9 – 18 (M25) mm		
Noise level	min. (if fan speed level I)	24.5	dB (A)
	max. (at fan speed level III)	39.5	dB (A)
Housing	material	ABS blend, UL 94-V0	
	Colour	grey 280 70 05 / anthracite violet 300 20 05	
Approvals	EN 54-20 / FM 3230-3250 / NFPA 72		
Dimensions	SEC-ASD 532 (W x H x D, without/with packaging)	195 x 333 x 140 / 215 x 355 x 160 mm	
	SSD 532-x (W x H x D, with packaging)	128 x 130 x 175 mm	
Weight	SEC-ASD 532 (without/with packaging)	1,700 / 1,950 g	
	SSD 532-x (with packaging)	335 g	



- ① Power consumption at maximum permitted voltage drop in the electrical installation (decisive value for calculating the conductor cross-section).
- ② May cause the protective circuit to trigger immediately in the case of power supplies with overload protective circuits (primarily in devices with no emergency power supply and output current of < 1.5 A).
- ③ Lower or higher temperature ranges are also possible subject to consultation with the manufacturer. The manufacturer must be consulted if the device is used in the condensation range.